

HP 355C  
HP 355D  
HP 355E  
HP 355F

# OPERATING AND SERVICE MANUAL

**355C**  
**355D**  
**355E**  
**355F**

## VHF ATTENUATOR

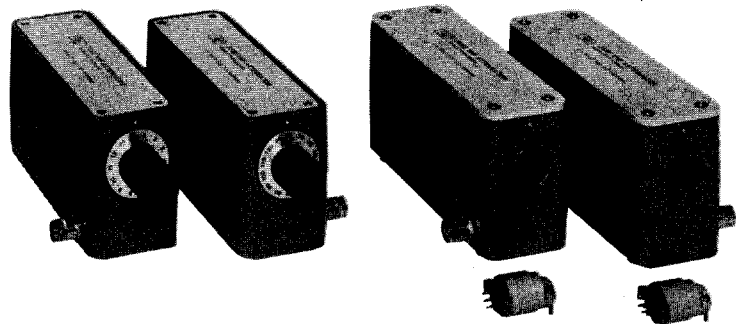

Printed: AUGUST 1980

 **HEWLETT  
PACKARD**

HP 355C  
HP 355D  
HP 355E  
HP 355F

## GENERAL INFORMATION

This manual contains operating instructions for Hewlett-Packard Model 355C, 355D, 355E, and 355F VHF Attenuators. Included in the manual is the information required to install and test these attenuators.

On the rear cover of this manual, below the manual part number, is a "Microfiche" part number. This number may be used to order a 100 x 150 mm (4 x 6 in.) microfilm transparency of the manual. The microfiche package also includes the latest Manual Changes supplement as well as all pertinent Service Notes.

### Specifications

Instrument specifications are listed in Table 1. These specifications are the performance standards or limits against which the instruments may be tested.

### Description

The Hewlett-Packard Model 355C, 355D, 355E, and 355F Attenuators are 50-ohm, coaxial step attenuators usable from dc to 1 GHz. Models 355C and 355E provide 0 to 12 dB of attenuation in 1 dB steps.

Models 355D and 355F provide 0 to 120 dB of attenuation in 10 dB steps. The 355C and 355D are manual attenuators. The 355E and 355F are programmable. The schematic for the Model 355C/D is shown in Figure 1 and that of the Model 355E/F in Figure 2.

The attenuator sections consist of resistor pi networks which are switched in or bypassed by microswitches. In the 355C and 355D the microswitches are actuated by cams (see Figure 1). In the 355E and 355F the microswitches are actuated by solenoids (see Figure 2). The standard RF connectors are BNC type.

In the 355E and 355F power must be continuously applied to the solenoid to actuate the microswitch (i.e., to insert an attenuator section). Each solenoid draws approximately 0.1A at 15 Vdc.

### Warranty

Attenuators are warranted only when they are operated within their specifications, especially power handling capability. Any attenuators returned to Hewlett-Packard under warranty will be examined carefully to determine if the failure was due to improper use. Be sure to observe the following caution.

Table 1. Specifications

<p><b>MODELS 355C and 355E</b></p> <p>Attenuation Range: 0 to 12 dB.            Attenuation Steps: 1 dB.            Overall Accuracy: 0.1 dB at 1000 Hz.                                      0.25 dB, dc to 500 MHz.                                      0.35 dB, dc to 1000 MHz.</p>	<p>Maximum SWR (input and output):            1.2 below 250 MHz;            1.3 below 500 MHz;            1.5 below 1000 MHz.</p>															
<p><b>MODELS 355D and 355F</b></p> <p>Attenuation Range: 0 to 120 dB.            Attenuation Steps: 10 dB.            Overall Accuracy: at 1000 Hz, 0 to 120 dB, <math>\pm 0.3</math> dB;                                      Below 1000 MHz, 0 to 90 dB, <math>\pm 1.5</math> dB;                                      90 to 120 dB, <math>\pm 3</math> dB.</p>	<p>Maximum Residual Attenuation:            Less than 0.25 dB to 100 MHz;            Less than 0.75 dB to 500 MHz;            Less than 1.5 dB to 1000 MHz.</p>															
<p><b>MODELS 355E and 355F</b></p> <p>Switching Speed: 65 ms.            Required Solenoid Power: +15 to +18 Vdc, 1/8 A.</p>	<p>Maximum Power Dissipation: 0.5W, average.            Maximum Pulse Voltage: 350 Vpk.            Connectors: BNC, female.            Dimensions:<sup>1</sup></p>															
<p><b>MODELS 355C/E and 355D/F</b></p> <p>Frequency Range: dc to 1000 MHz.            Impedance: 50 ohms (nominal).</p>	<table border="0"> <thead> <tr> <th></th> <th><b>355C and 355D</b></th> <th><b>355E and 355F</b></th> </tr> </thead> <tbody> <tr> <td>Length:</td> <td>152 mm (6 in.)</td> <td>139 mm (5 7/16 in.)</td> </tr> <tr> <td>Width:</td> <td>71 mm (2 13/16 in.)</td> <td>71 mm (2 13/16 in.)</td> </tr> <tr> <td>Height:</td> <td>68 mm (2 11/16 in.)</td> <td>71 mm (2 11/16 in.)</td> </tr> <tr> <td>Weight:</td> <td colspan="2">0.67 kg (1.5 lb).</td> </tr> </tbody> </table>		<b>355C and 355D</b>	<b>355E and 355F</b>	Length:	152 mm (6 in.)	139 mm (5 7/16 in.)	Width:	71 mm (2 13/16 in.)	71 mm (2 13/16 in.)	Height:	68 mm (2 11/16 in.)	71 mm (2 11/16 in.)	Weight:	0.67 kg (1.5 lb).	
	<b>355C and 355D</b>	<b>355E and 355F</b>														
Length:	152 mm (6 in.)	139 mm (5 7/16 in.)														
Width:	71 mm (2 13/16 in.)	71 mm (2 13/16 in.)														
Height:	68 mm (2 11/16 in.)	71 mm (2 11/16 in.)														
Weight:	0.67 kg (1.5 lb).															
<p><sup>1</sup>Dimensions are for general information only. If dimensions are required for building special enclosures, contact your HP office.</p>																

**CAUTION**

*Do not exceed the RF power rating of 0.5W average, or 2450W peak with a maximum pulse width of 200  $\mu$ s. Do not connect an attenuator RF input or output connector to greater than  $\pm 5$  Vdc. If the attenuator must be connected to a device with a potential greater than  $\pm 5$  Vdc, use a blocking capacitor.*

**Accessories Supplied**

The 355E and 355F programmable attenuators are supplied with a 7 pin, male connector (HP 1251-1037) for the solenoid drive input.

**Options**

Table 2 lists the options available.

**INSTALLATION****Initial Inspection**

Inspect the shipping container for damage. If the shipping container or cushioning material is damaged, it should be kept until the contents of the shipment have been checked mechanically and electrically. A procedure for checking electrical performance is given under "Operator's Check" (see PERFORMANCE TESTS). If the contents of the shipment are incomplete, if there is mechanical damage or defect, or if the instrument does not pass the electrical performance test, notify the nearest Hewlett-Packard office. If the shipping container is damaged, or the cushioning material shows signs of stress, notify the carrier as well as the Hewlett-Packard office. Keep the shipping materials for the carrier's inspection.

**Mating Connectors**

Mating RF input and output connectors used with the attenuators should be:

- Standard: Type BNC.
- Option 001: Type N.
- Option 005: Type TNC.

For the 355E and 355F, the solenoid drive connector plug is 7-pin male (HP 1251-1037).

**Operating Environment**

The operating environment of the instrument should be within the following limitations:

Temperature: 0 to  $+55^{\circ}$  C.

Humidity:  $<95\%$  relative.

Altitude:  $<4570$  m (15 000 ft).

**Storage and Shipment**

**Environment.** The instrument should be stored in a clean, dry environment. The following environmental limitations apply to both storage and shipment:

Temperature:  $-40^{\circ}$  C to  $+75^{\circ}$  C

Humidity:  $<95\%$  relative

Altitude:  $<7620$  m (25 000 ft).

**Original Packaging.** Containers and materials identical to those used in factory packaging are available through Hewlett-Packard offices. If the instrument is being returned to Hewlett-Packard for servicing, attach a tag indicating the type of service required, return address, model number, and full serial number. Also, mark the container FRAGILE to assure careful handling. In any correspondence, refer to the instrument by model number and full serial number.

**OPERATING INSTRUCTIONS****CAUTION**

*Do not apply RF power greater than 0.5W average, or 2450W peak with a maximum pulse width of 200  $\mu$ s. If these limits are exceeded, the Attenuator may be damaged.*

Either RF connector may be used as the input or output connector, except in the case of the 355D/F driven from a low impedance source. This is because the leaf switch (Figures 1 and 2) may be closed before the microswitch opens when the dial is switched from 50 dB to 60 dB. Should this occur, a momentary short is placed across the connector, inviting damage to either the microswitch or the signal source. Therefore, if the signal source is subject to damage by a short, use the rear most connector for the input. (The dial or solenoid connector is at the front of the attenuator.) This pads the momentary short with 50 dB of isolation. For the 355E and 355F, wire the solenoid drive plug supplied using Figure 3 as a wiring guide. An un-energized attenuator solenoid section is 0 dB. Apply  $+15$  to  $+18$  Vdc (with respect to pin H) to energize an attenuator solenoid. A programming table is also given in Figure 3.

MODELS 355C AND 355D

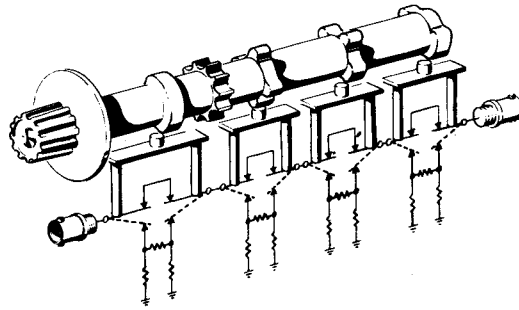

MODEL 355C

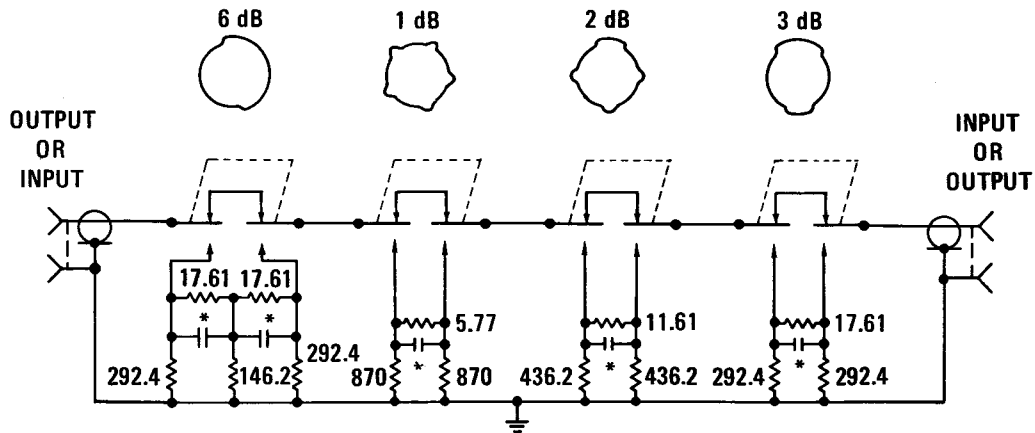

MODEL 355D

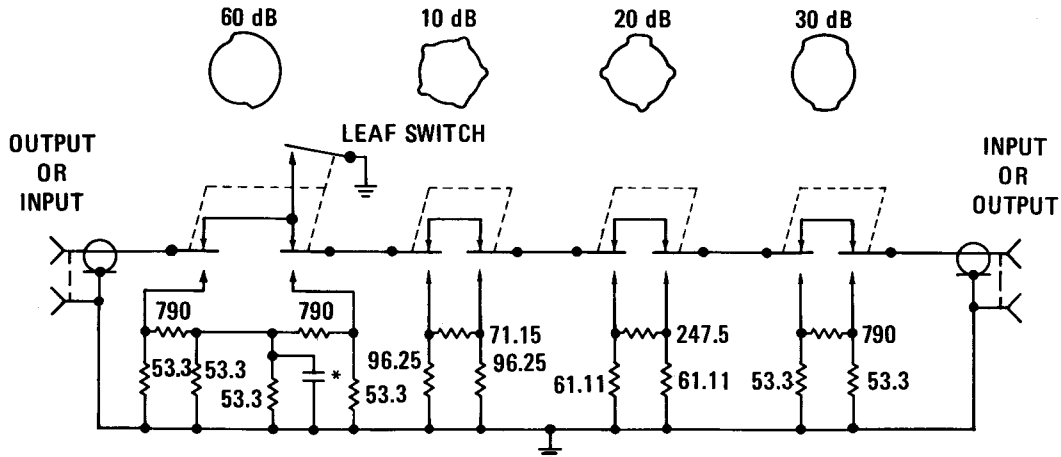

NOTES

1. Microswitches shown in 0 dB position.
2. Resistances in ohms ( $\pm 1/2\%$ ).
3. Capacitance values factory-adjusted.
4. \*Asterisk denotes factory selected value.

Figure 1. Schematic Diagrams, Models 355C and 355D

MODELS 355E AND 355F

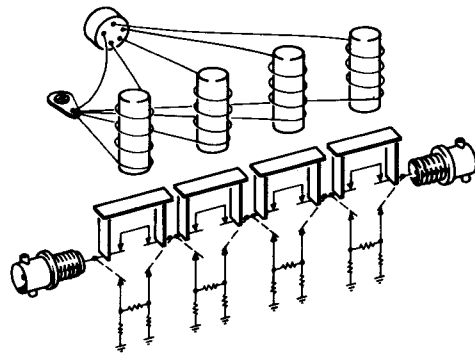

MODEL 355E

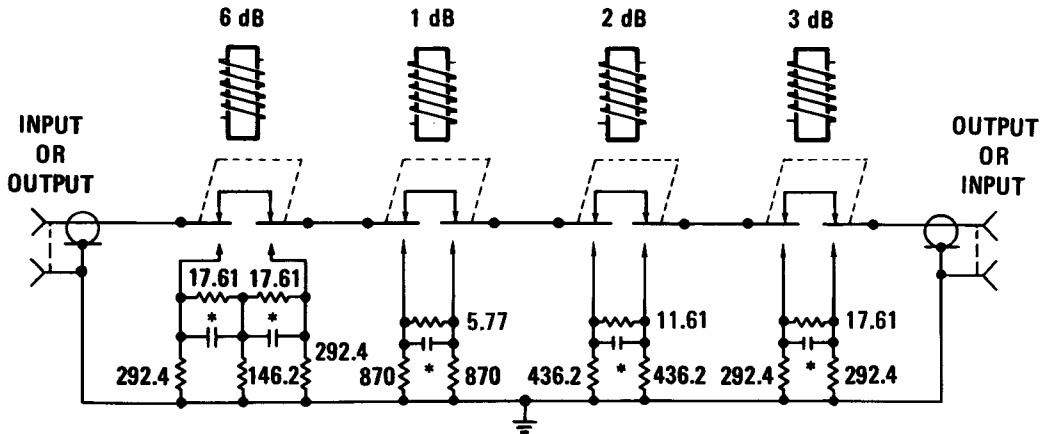

MODEL 355F

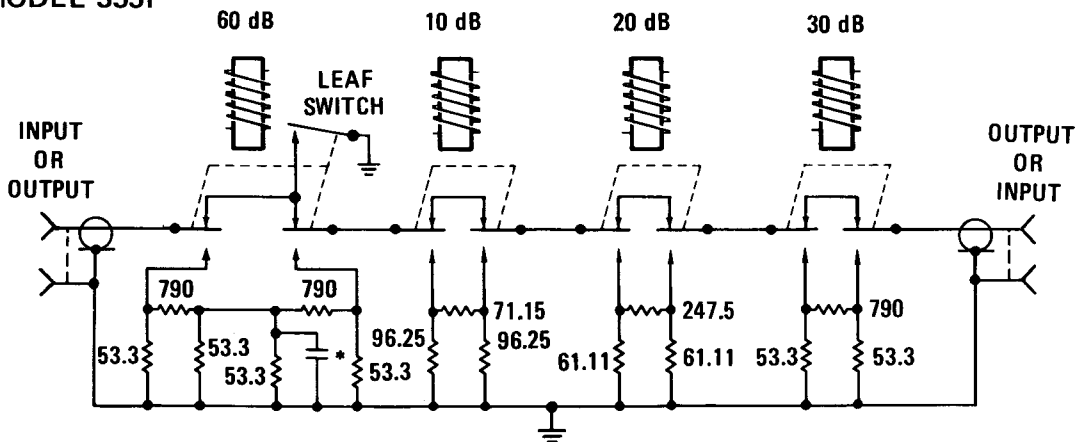

NOTES

1. Microswitches shown in 0 dB position.
2. Resistances in ohms ( $\pm 1/2\%$ ).
3. Capacitance values factory-adjusted.
4. \*Asterisk denotes factory selected value.

Figure 2. Schematic Diagrams, Models 355E and 355F

**Table 2. Attenuator Options**

**Models 355C and 355D**

- Option 001 - Type N input and output connectors.
- Option 003 - Modifies the 355C or 355D to provide panel mounting capability by incorporating the following changes:
  1. The attenuator shaft is 3/16" longer, thereby allowing the instrument shaft to protrude through a 3/16" panel.
  2. Four 6-32 holes are drilled and tapped in the instrument casting to allow the instrument to be mounted to a panel.
  3. A 1 3/4" dial is added. (This dial is larger than that used with the standard Models 355C/D.)

**NOTE**

*Panel drilling detail for mounting Option 003 is as follows:*

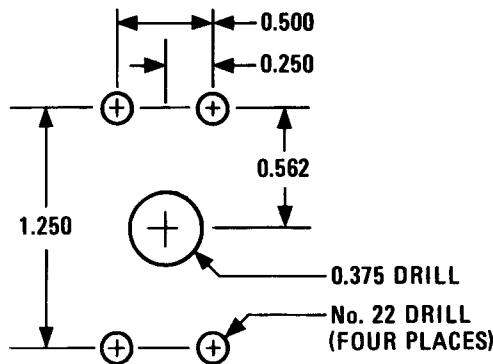

Option 005 - Type TNC input and output connectors.

**Models 355E and 355F**

Option 007 - Adds transistor driver protection circuitry as follows:

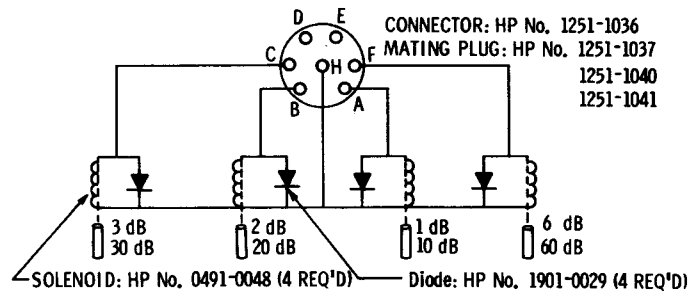

**NOTE**

*Pin H must be positive with respect to other pins.*

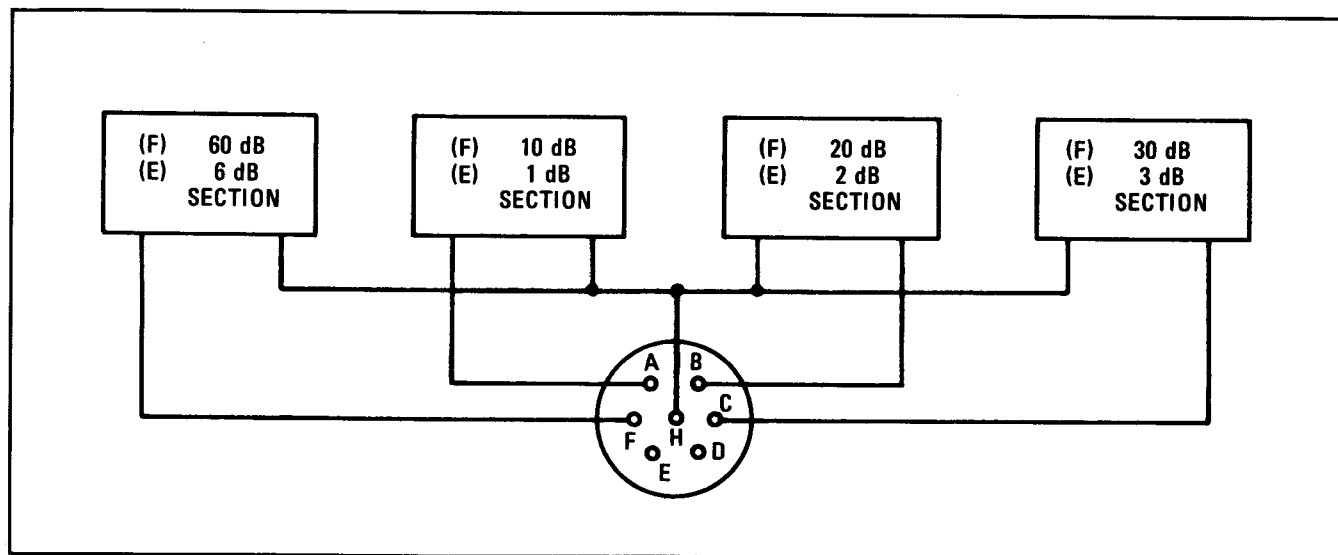

To obtain attenuation settings given below, apply +15 to +18 Vdc between Pin H (common) and Pins:

355E	355F	Pins	355E	355F	Pins
1 dB	10 dB	A	7 dB	70 dB	F, A
2 dB	20 dB	B	8 dB	80 dB	F, B
3 dB	30 dB	C	9 dB	90 dB	F, C
4 dB	40 dB	C, A	10 dB	100 dB	F, C, A
5 dB	50 dB	C, B	11 dB	110 dB	F, C, B
6 dB	60 dB	F	12 dB	120 dB	F, C, B, A

Figure 3. 355E and 355F Solenoid and Connector Wiring and Programming

### OPERATOR'S CHECK

**DESCRIPTION:** The attenuator is driven from a 50 ohm signal source at 1 kHz. The output level from the attenuator is detected by a narrow-bandwidth voltmeter (that is, the SWR meter). The attenuator and detector range switches are stepped together and the variations in level noted. This verifies that each attenuator section is being properly switched and checks the low-frequency accuracy of the attenuator.

#### NOTE

*The SWR Meter used in this check is calibrated for a square-law detector and therefore the range changes and errors (read in dB) are twice that indicated by the meter.*

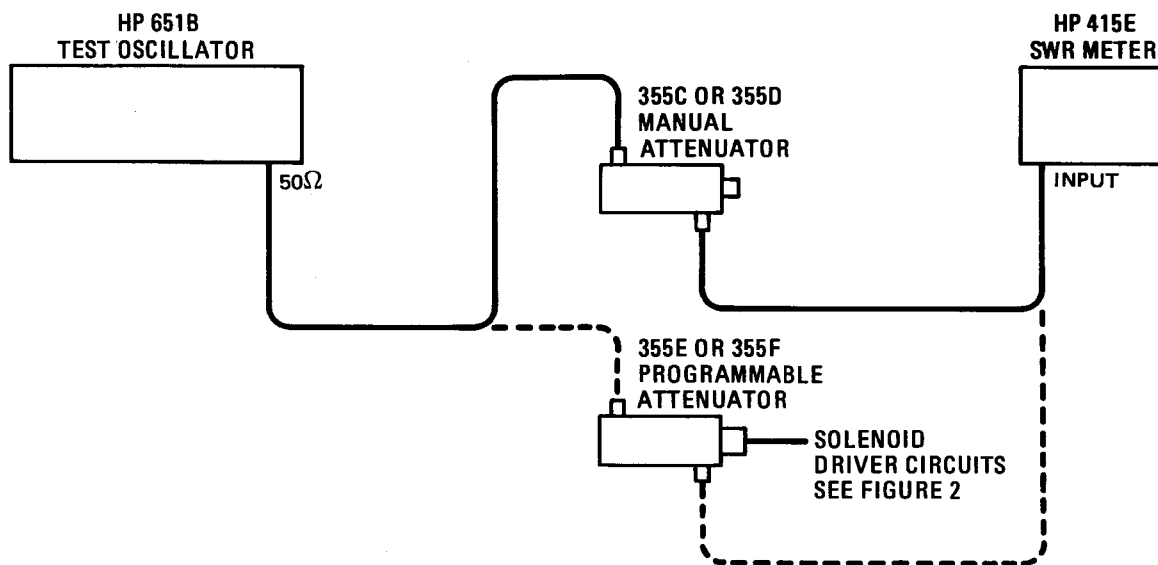

- PROCEDURE:**
1. Connect equipment as shown above with Attenuator set to 0 dB attenuation.
  2. Set Test Oscillator to 0.3 Vrms at 1 kHz.
  3. Set the SWR Meter input to XTAL IMPED LOW and the range to 2 dB (expanded) for 355D or 355F or to 10 dB (with 0 dB expand) for 355C or 355E. Adjust its bandwidth to the center of the adjustment range. Fine tune oscillator frequency to obtain the maximum meter indication.
  4. Set attenuator and SWR Meter range switch as listed in table next page, and verify that the SWR Meter indicates within the limits shown.

Figure 4. Operator's Checks (1 of 2)



OPERATOR'S CHECKS

355C And 355E				
SWR Meter Range (dB)	Attenuation (dB)	Meter Indication (dB)		
		Min.	Actual	Max.
10	0		Set to 0.0	
10	1	0.45	_____	0.55
10	2	0.95	_____	1.05
10	3	1.45	_____	1.55
10*	4	1.95	_____	2.05
	5	0.45	_____	0.55
12	6	0.95	_____	1.05
12	7	1.45	_____	1.55
12*	8	1.95	_____	2.05
14	9	0.45	_____	0.55
14	10	0.95	_____	1.05
14	11	1.45	_____	1.55
14*	12	1.95	_____	2.05
355D And 355F				
SWR Meter Range (dB)	Attenuation (dB)	Meter Indication (dB)		
		Min.	Actual	Max.
2	0		Set to 0.5	
6	10	1.35	_____	1.65
12	20	0.35	_____	0.65
16	30	1.35	_____	1.65
22	40	0.35	_____	0.65
26	50	1.35	_____	1.65
32	60	0.35	_____	0.65
36	70	1.35	_____	1.65
42	80	0.35	_____	0.65
46	90	1.35	_____	1.65
52	100	0.35	_____	0.65
56	110	1.35	_____	1.65
62	120	0.35	_____	0.65
*Adjust range by 2 dB, if needed to obtain an on-scale indication.				

Figure 4. Operator's Checks (2 of 2)

**OPERATOR'S CHECK**

The Operator's Check (Figure 4) is supplied to allow the operator to make a quick check of the attenuator prior to use or if a failure is suspected.

**PERFORMANCE TESTS**

The attenuator can be tested to the accuracy of the specifications in Table 1 with an Automatic Network Analyzer or equivalent equipment of suitable accuracy. If an Automatic Network Analyzer is available, test the attenuator using the procedures in the analyzer's operating manual. The 355E and 355F attenuators must be programmed by a suitable circuit to provide the various values of attenuation (see Figure 3).

**ADJUSTMENTS**

The attenuators have no internal adjustments and should not be opened. If defective, return the attenuator to the nearest Hewlett-Packard office for repair.

**CAUTION**

*The solenoids in the 355E and 355F have been precisely adjusted at the factory. No attempt should be made to replace them except by factory approved service representatives. The operation of the attenuators will be unreliable if plungers are not kept with their proper solenoids. Do not interchange or "swap" them.*

**REPLACEABLE PARTS**

Table 3 lists the replaceable parts which are the only parts that can be replaced without access to the interior of the attenuator.

If any parts not listed in Table 3 need replacement, return the instrument to Hewlett-Packard.

To order a part listed in the replaceable parts table, quote the Hewlett-Packard part number with check digit (CD), indicate the quantity required, and address the order to the nearest Hewlett-Packard office.

**NOTE**

*Within the USA, it is better to order directly from the HP Parts Center in Mt. View, California. Ask your nearest HP office for information and forms for the "Direct Mail Order System".*

**SERVICE**

**Troubleshooting**

Troubleshooting consists of performing the Operator's Check shown in Figure 4. If the instrument does not perform within limits, return the instrument to Hewlett-Packard.

**CAUTION**

*Due to special fixtures necessary for assembly, do NOT attempt to replace any parts not listed in Table 3. If the instrument is opened, the warranty is void.*

**Table 3. Replaceable Parts**

		<b>CD</b>
<b>355C</b>		
Glide (feet) 4 each . . . . .	HP 0403-0026	7
Dial Assembly . . . . .	HP 355A-40G	0
Dial Assembly (Option 003). . . . .	HP 00355-00001	5
<b>355D</b>		
Glide (feet) 4 each . . . . .	HP 0403-0026	7
Dial Assembly . . . . .	HP 355A-40H	8
Dial Assembly (Option 003). . . . .	HP 00355-00002	6
<b>355E and 355F</b>		
Glide (feet) 4 each . . . . .	HP 0403-0026	6
Connector, 7 pin (male) . . . . .	HP 1251-1037	9

## CERTIFICATION

*Hewlett-Packard Company certifies that this product met its published specifications at the time of shipment from the factory. Hewlett-Packard further certifies that its calibration measurements are traceable to the United States National Bureau of Standards, to the extent allowed by the Bureau's calibration facility, and to the calibration facilities of other International Standards Organization members.*

## WARRANTY

This Hewlett-Packard instrument product is warranted against defects in material and workmanship for a period of one year from date of shipment. During the warranty period, Hewlett-Packard Company will, at its option, either repair or replace products which prove to be defective.

For warranty service or repair, this product must be returned to a service facility designated by HP. Buyer shall prepay shipping charges to HP and HP shall pay shipping charges to return the product to Buyer. However, Buyer shall pay all shipping charges, duties, and taxes for products returned to HP from another country.

HP warrants that its software and firmware designated by HP for use with an instrument will execute its programming instructions when properly installed on that instrument. HP does not warrant that the operation of the instrument, or software, or firmware will be uninterrupted or error free.

## LIMITATION OF WARRANTY

The foregoing warranty shall not apply to defects resulting from improper or inadequate maintenance by Buyer, Buyer-supplied software or interfacing, unauthorized modification or misuse, operation outside of the environmental specifications for the product, or improper site preparation or maintenance.

NO OTHER WARRANTY IS EXPRESSED OR IMPLIED. HP SPECIFICALLY DISCLAIMS THE IMPLIED WARRANTIES OF MERCHANTABILITY AND FITNESS FOR A PARTICULAR PURPOSE.

## EXCLUSIVE REMEDIES

THE REMEDIES PROVIDED HEREIN ARE BUYER'S SOLE AND EXCLUSIVE REMEDIES. HP SHALL NOT BE LIABLE FOR ANY DIRECT, INDIRECT, SPECIAL, INCIDENTAL, OR CONSEQUENTIAL DAMAGES, WHETHER BASED ON CONTRACT, TORT, OR ANY OTHER LEGAL THEORY.

## ASSISTANCE

*Product maintenance agreements and other customer assistance agreements are available for Hewlett-Packard products.*

## HEWLETT-PACKARD SERVICE OFFICES

To obtain servicing information, contact the nearest Hewlett-Packard Sales and Service Office in HP Catalog, or contact the nearest regional office listed below.

### UNITED STATES

NO. CALIFORNIA (San Francisco Area)  
333 Logue Ave.  
Mt. View, CA 94043

SO. CALIFORNIA (Los Angeles Area)  
5400 West Rosecrans Blvd.  
Lawndale, CA 90260

GEORGIA  
450 Interstate N. Parkway  
Atlanta, GA 30348

ILLINOIS  
5201 Tollview Dr.  
Rolling Meadows, IL 60008

NEW JERSEY  
W. 120 Century Rd.  
Paramus, NJ 07652

### AUSTRALIA

Hewlett-Packard Australia Ltd.  
31-41 Joseph Street  
Blackburn, Victoria 3130

### CANADA

Hewlett-Packard (Canada) Ltd.  
6877 Goreway Drive  
Mississauga, Ontario  
Canada L4V 1M8

### ITALY

Hewlett-Packard Italiana S.p.A.  
Via G. Di Vittorio, 9  
20063 Cernusco  
Sul Naviglio (MI)

### FRANCE

Hewlett-Packard France  
Quartier de Courtaboeuf  
Boite Postale No. 6  
F-91401 Orsay Cedex

### GERMAN FEDERAL REPUBLIC

Hewlett-Packard GmbH  
Vertriebzentrale Frankfurt  
Bernerstrasse 117  
Postfach 560 140  
D-6000 Frankfurt 56

### NETHERLANDS

Hewlett-Packard Benelux N.V.  
Van Heuven Doedhartlaan 121  
P.O. Box 667  
NL-Amstelveen 1134

### UNITED KINGDOM

Hewlett-Packard Ltd.  
King Street Lane  
GB-Winnersh, Wokingham  
Bers, RG11 5AR

### AFRICA, ASIA, CENTRAL AND SOUTH AMERICA

Hewlett-Packard Intercontinental  
3200 Hillview Avenue  
Palo Alto, CA 94304



HP Part No. 00355-90045  
Microfiche Part No. 00355-90046

Printed in U.S.A.